

INSTALLATION GUIDE

L-Side Series

WARNING

Electrical shock risk. Do not modify these products, as any alterations may void the warranty and compromise safety. Installation requires knowledge of electrical sign systems; if you are not qualified, please consult a certified electrician. Always disconnect the power supply before installing the product. Ensure the correct driver (12V or 24V) and adequate maximum wattage are used. Adhere to the specified guidelines for optimal results.

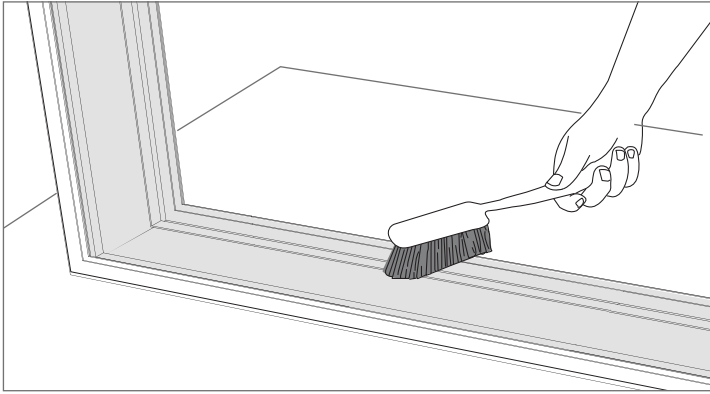

1 Clean the inside of your lightbox, ensuring it is free from any debris or dirt.

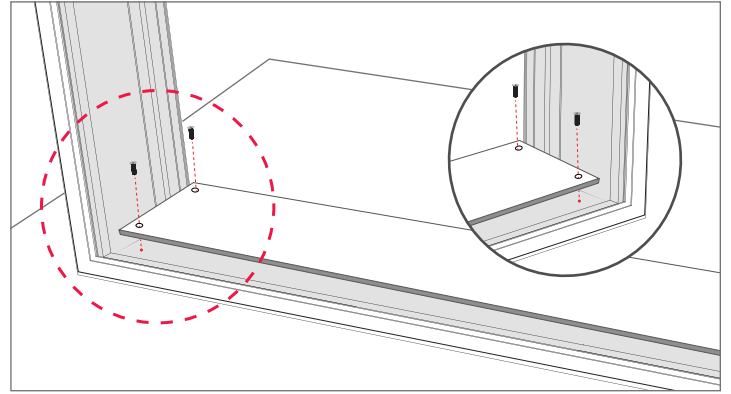

2 Before installing the LEDs, screw the ACM panel to the bottom of the extrusion bar frame. (refer to Figure 1 on page 2).

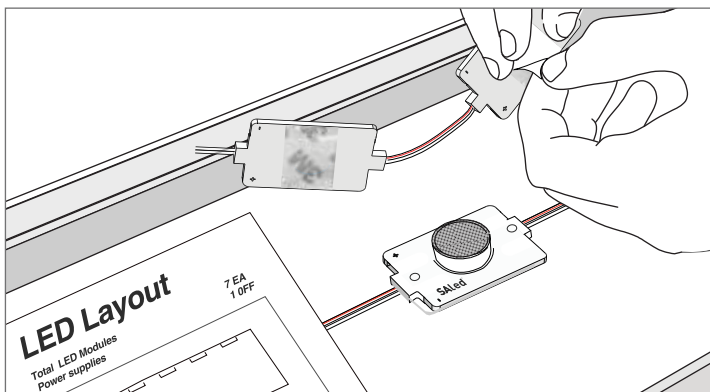

3 Remove the tape from the back of the LEDs and stick them in **ACM panel** according to the provided layout (refer to Figure 1 on page 2).

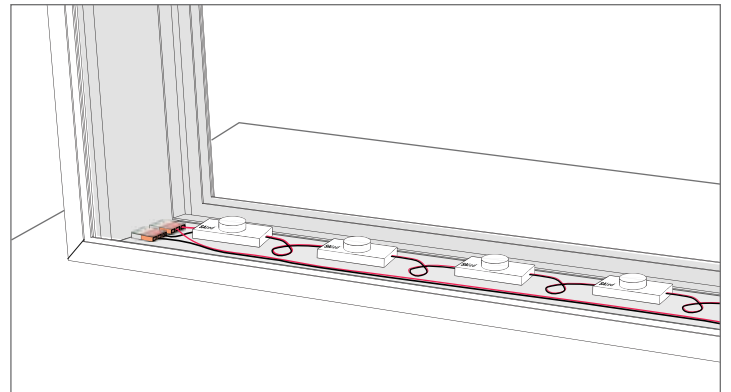

4 Ensure modules are connected in series or parallel (refer to Figure 2 on page 2). Avoid exceeding the maximum module count. WAGO connectors enable quick wiring of LEDs.

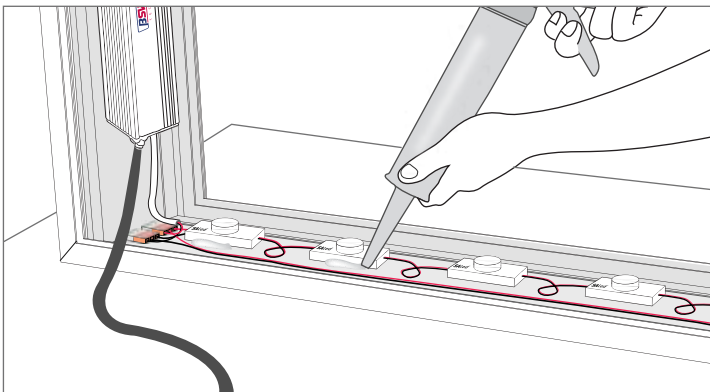

5 Secure the LEDs with silicone glue. Fix the power supply to the inside of the lightbox with screws, and wire both ends of the LED modules to the power supply (refer to page 2)

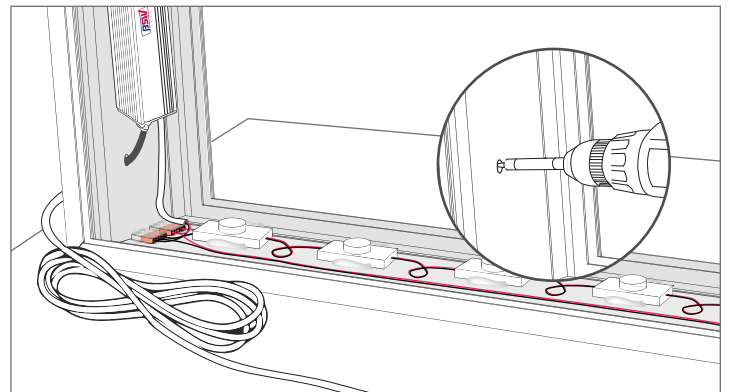

6 Drill holes on lightbox connect to the power supply.
*We recommend drilling a 6mm drain hole in the bottom of the lightbox.

INSTALLATION GUIDE

L-Side Series

Figure 1. LED Modules pitch guide.

We recommend using lightboxes with the following depths based on the LED module specifications.

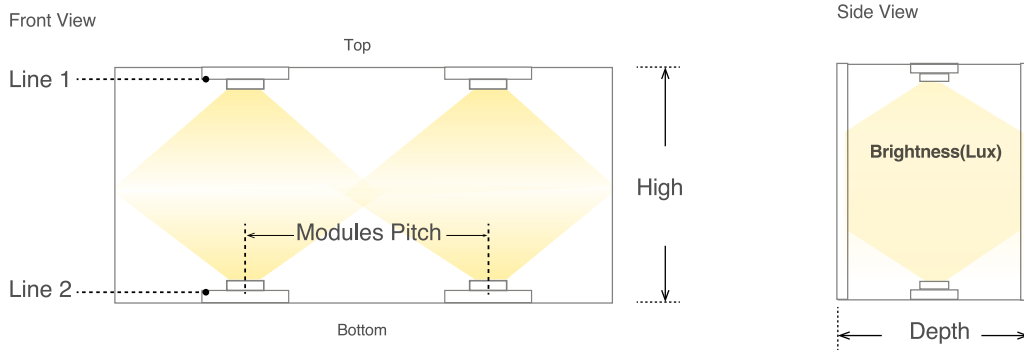

Item Code	Depth	High	Module Pitch (*CTC)	Run	Max in Series
SA 4161	150mm	Up to 600mm	100mm	One line	10 Modules
	200mm	From 601~1000mm	100mm	Two line	
SA 4181	150mm	Up to 800mm	100mm	One line	20 Modules
	200mm	From 801~1200mm	100mm	Two line	

*Center to Centre

Figure 2. Wiring Diagram

Check Polarity : All connections must be **RED-TO-RED (+)** and **BLACK-TO-BLACK(-)**. Reverse polarity connections may damage the LEDs and will void the product warranty.

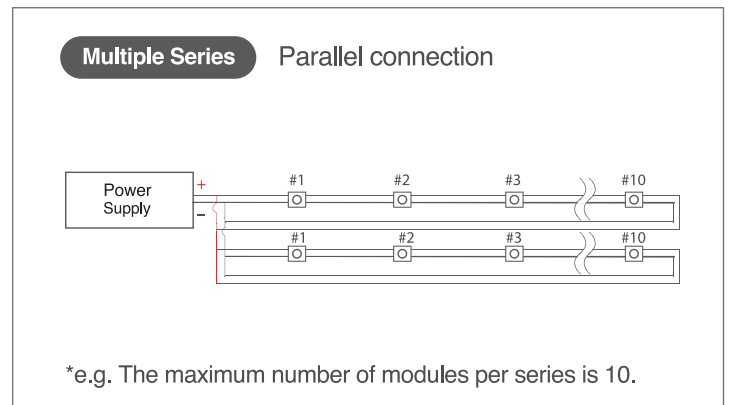
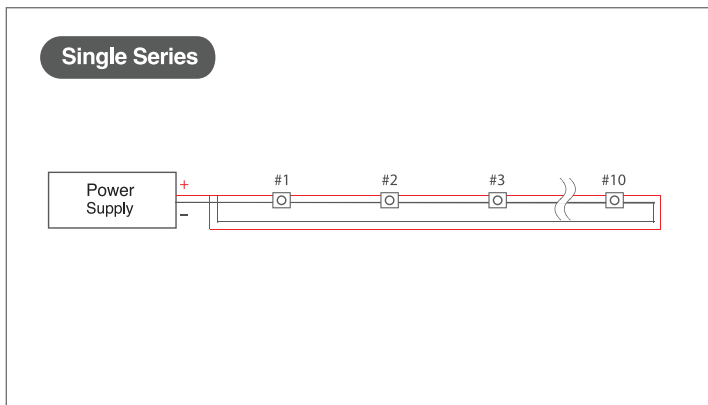

Do not exceed the maximum number of LED modules per series (refer to each item's spec sheet for specific numbers). We recommend wiring both ends of LED modules to the power supply.

If you require **multiple modules**, they must be wired in parallel as a safe electrical operation mode. **Serial connection is not recommended**, as unbalanced voltage drops can lead to hazardous overload, potentially damaging the LED modules and causing uneven brightness.